

**SPECIFICATIONS: RS117060 TOP DOWN FURLER ADAPTOR**

**SUITS THE 170 SERIES FURLERS (not 170R)**

**RS117060 - TOP DOWN FURLER ADAPTOR**

- MWL = 1500kg (3300lb)
- BL = 3000kg (6600lb)
- MOUNTING SCREWS = M6 x 20mm SS316 CSK CAPSCREWS
- WEIGHT = 490g (17.3oz)

THE DOCUMENT & THE DESIGN ON IT IS THE EXCLUSIVE PROPERTY OF RONSTAN INTERNATIONAL PTY. LTD. & IS THE SUBJECT OF COPYRIGHT.



[www.ronstan.com](http://www.ronstan.com)

|          |                |
|----------|----------------|
| DATE     | ALL DIMS IN MM |
| 20/09/11 | DO NOT SCALE   |

TITLE **Top Down Attachment, S170**

**A4**



## RS117060 Top Down Furler Adaptor

### Installation Instructions

#### SUITS THE SERIES 170 (RS017000) FURLER

**What you will need:** Metric Allen/Hex key (#3 & #4), Tef-Gel® TG-10.

#### Step 1

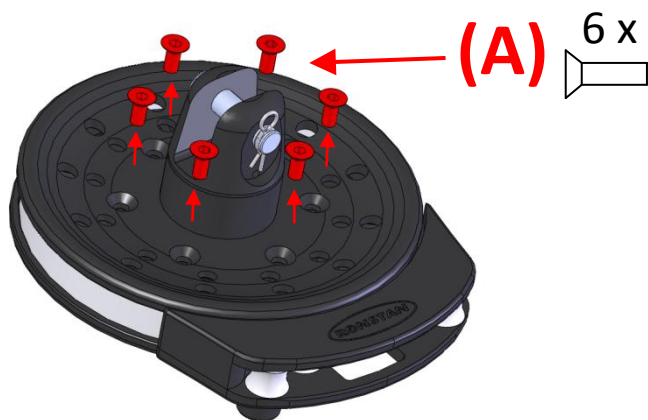

#### Step 2

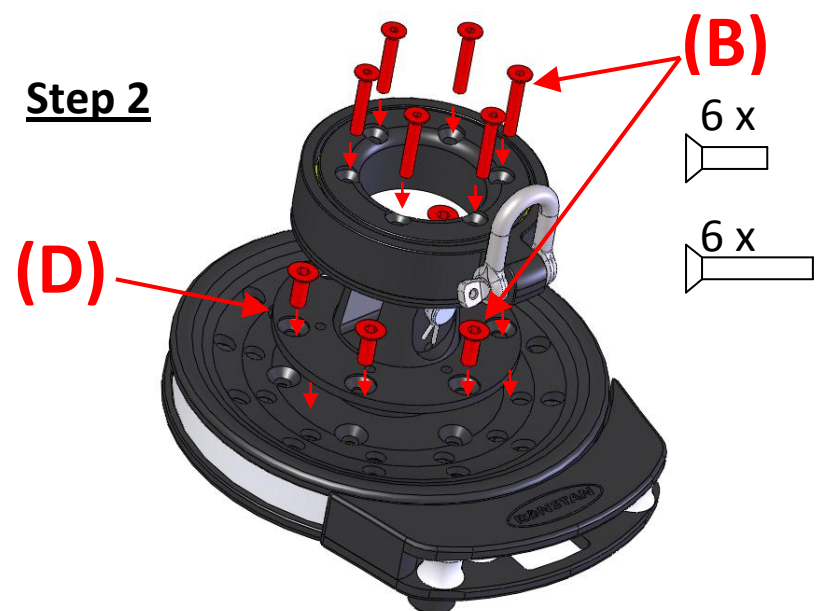

#### Step 3

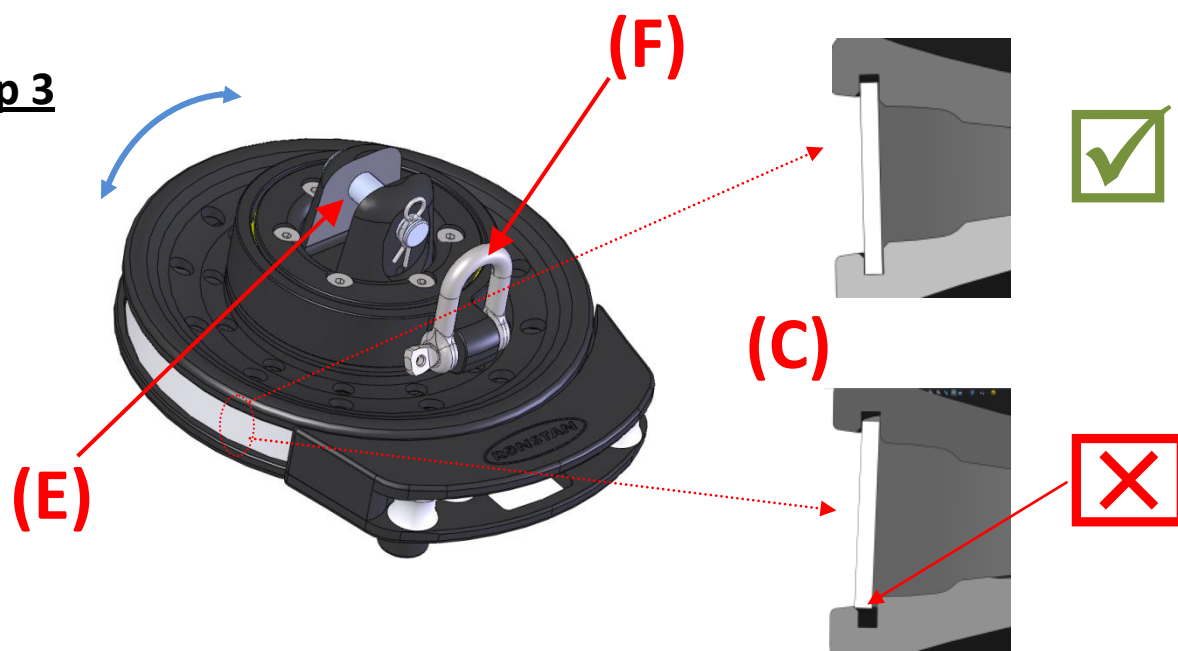

#### Step 4

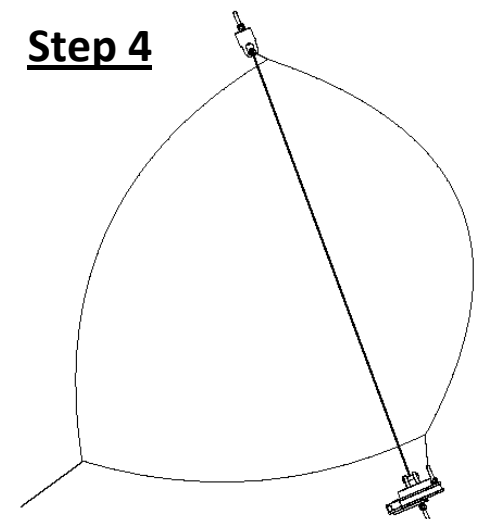

- Step 1 – Remove the 6 existing screws (A) holding the 2 furler plates in position. Be careful not to drop the white PTFE strip (C) as it will become free once the screws (A) are removed.
- Step 2 – Lower the adaptor mounting plate (D) over the furler fork down in to position. Fasten using the 6 x M6 screws provided. Add Tef-Gel® to all screws (B) before re-assembly to prevent corrosion around the stainless steel fasteners. Lower the swivel adaptor on to the mounting plate. Fasten using the 6 x M5 screws provided.
- Step 3 – Swivel the drum by hand to check that it spins freely over the white PTFE strip (C).
- Step 4 – Attach the anti-torsion line to the furler fork and clevis pin (E). Attach the tack of the gennaker to the shackle provided (F).

#### **Maintenance:**

- Rinse regularly with fresh water to remove salt.
- Apply Ronstan RF3000 Sailfast (or a similar silicon based lubricant) over the body and components to enhance performance and prolong service life.
- Periodically remove fasteners and re-apply Tef-Gel® (TG-10) to prevent corrosion.
- Furlers have a three year warranty – refer to [www.ronstan.com](http://www.ronstan.com) for terms and conditions.

